

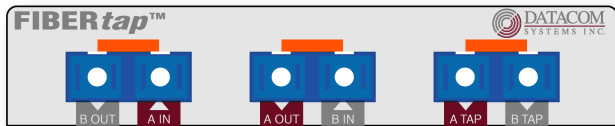

Datacom Systems Inc

Access Your Network™



Single 1G TAP

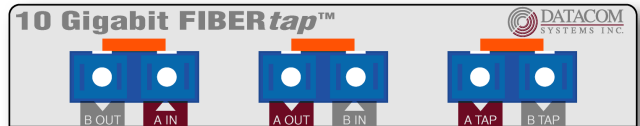

Single 10G TAP

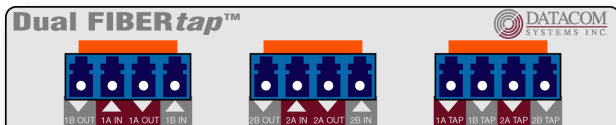

Dual 1G TAP

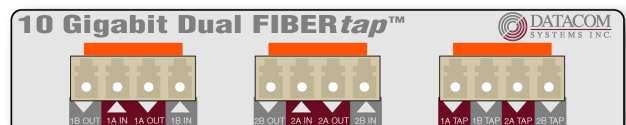

Dual 10G TAP

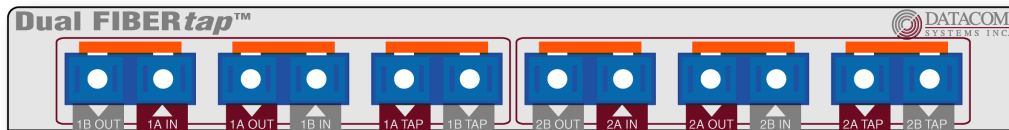

Dual 1G SC TAP

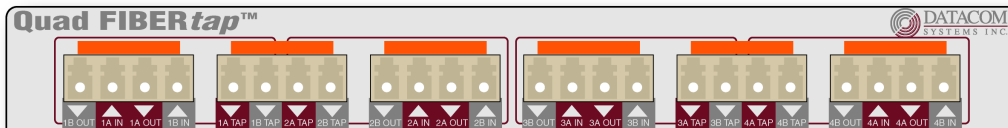

Quad 1G TAP

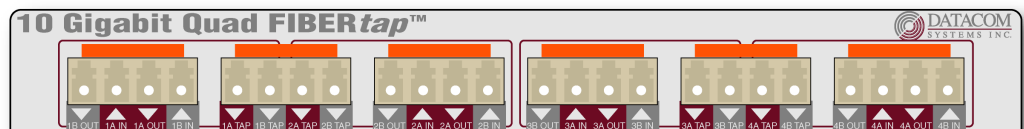

Quad 10G TAP

Single, Dual and Quad Fiber TAPs

QUICKinstall

March 2009

541-0117-U-A.00

Product Description

Datacom Systems Inc. 1 Gigabit and 10 Gigabit Single, Dual or Quad FIBERTap™ provide an easy method to passively monitor fiber network traffic flowing between devices using your network analysis tools. Using your passive FIBERTap™, your network analysis tools can be quickly and effectively deployed to the point of failure. Typically the passive FIBERTap™ is installed on a critical fiber link in the network where monitoring and analysis capabilities are important.

Single, Dual and Quad Fiber TAPs

© 2009 Datacom Systems Inc

All rights reserved. No parts of this work may be reproduced in any form or by any means - graphic, electronic, or mechanical, including photocopying, recording, taping, or information storage and retrieval systems - without the written permission of the publisher.

Products that are referred to in this document may be either trademarks and/or registered trademarks of the respective owners. The publisher and the author make no claim to these trademarks.

While every precaution has been taken in the preparation of this document, the publisher and the author assume no responsibility for errors or omissions, or for damages resulting from the use of information contained in this document or from the use of programs and source code that may accompany it. In no event shall the publisher and the author be liable for any loss of profit or any other commercial damage caused or alleged to have been caused directly or indirectly by this document.

Printed: April 2009 in East Syracuse, New York

Table of Contents

Section 1	Terms of Use	7
1	Copyright.....	7
2	License Agreement.....	7
3	Trademark Attribution.....	7
4	Proprietary Notice.....	7
5	Certifications and Marks.....	8
6	Safety Notices and Warnings.....	9
Section 2	Overview	10
1	Single TAP Summary.....	10
2	Dual TAP Summary.....	10
3	Quad TAP Summary.....	10
4	What Shipped?.....	11
5	Single TAP Specifications.....	12
6	Dual TAP Specifications.....	13
7	Quad TAP Specifications.....	14
Section 3	Functional and Front Panel Diagrams	15
1	Single TAP.....	15
2	Dual TAP.....	16
3	Quad TAP.....	17
Section 4	Hardware Installation	18
1	How Fiber TAPs Work.....	18
2	Single TAP.....	19
3	Dual LC TAP.....	20
4	Dual SC TAP.....	21
5	Quad TAP.....	23
Section 5	Customer Service	25
1	Internet.....	25
2	Warranty.....	25
3	Limits of Liability.....	26

1 Terms of Use

The following terms and conditions relate to the use of this document. Please note that Datacom Systems Inc. reserves the right, at its entire discretion, to change, modify, add, or remove portions of these Terms of Use at any time. Please read the Terms of Use carefully as your use of this document is subject to the Terms of Use stipulated herein.

1.1 Copyright

Copyright© 2009 by Datacom Systems, Inc. All rights reserved. Printed in the United States of America. No part of this publication may be reproduced, stored in a retrieval system, or transmitted, in any form or by any means, electronic, mechanical, photocopying, recording, or otherwise, without the prior written permission of Datacom Systems, Inc. To obtain this permission, write to the attention of the Datacom Systems legal department at 9 Adler Drive, East Syracuse, New York 13057-1290, or call 315-463-9541.

1.2 License Agreement

Notice To All Users: By using Datacom Systems, Inc. products, you agree to the terms set forth. No licenses, express or implied, are granted with respect to the technology described and Datacom Systems, Inc. retains all rights with respect to the technology described herein. If applicable, you may return the product to the place of purchase for a full refund.

1.3 Trademark Attribution

Access Your Network™, *DS3 ACTIVEtap™*, *DS3switch™*, *ETHERNETtap™*, *Empowering Network Professionals™*, *FDDIswitch™*, *FIBERSplitter™*, *FIBERswitch™*, *FIBERSWITCH-system™*, *FLOWcontrol™*, *GIGABITswitch™*, *INSERTswitch™*, *INSERTunit™*, *LANswitch™*, *MANAgents™*, *MULTINETswitch™*, *NETspan™*, *PERMALink™*, *PROline™*, *RMON SWITCHINGanalyzer™*, *SINGLEstream™*, *UNIVERSALswitch™*, *VERSAstream™*, and *WANswitch™* are trademarks of Datacom Systems, Inc. *1ST in Switching Solutions®*, *DATACOMsystems®*, *LANclipper®*, *MANAgents®*, and *MULTIview®* are registered trademarks of Datacom Systems, Inc. All other registered and unregistered trademarks are the sole property of their respective owners. All specifications may be changed without notice.

1.4 Proprietary Notice

This document contains proprietary information about the Single, Dual and Quad Fiber TAP family of products and is not to be disclosed or used except as authorized by written contract with Datacom Systems, Inc.

1.5 Certifications and Marks

CAUTION: Changes or modifications to this unit not expressly approved by the party responsible for compliance could void the user's authority to operate the equipment.



The RoHS compliant logo indicates that this electronic product does not exceed the limit requirements of toxic, hazardous substances or elements as set forth in Directive 2002/95/EC of the European Parliament and of the Council of 27 January 2003 on the restriction of the use of certain hazardous substances in electrical and electronic equipment.



The crossed out wheelie bin logo signifies that the product can be recycled after being discarded, and should not be casually discarded as set forth in Directive 2002/96/EC of the European Parliament and of the Council of 27 January 2003 on waste electrical and electronic equipment (WEEE).

1.6 Safety Notices and Warnings



These explanatory labels are included in this information for the user in accordance with the requirements of IEC 60825-1.



WARNING: Class 1 laser and LED product. A class 1 laser is safe under all conditions of normal use. Invisible laser radiation may be emitted from optical port openings when no fiber cable is connected, avoid exposure to laser radiation and do not stare into open optical ports.

2 Overview

The Single, Dual and Quad family of TAP products increases network visibility and leverages your investment in network analyzers, probes, and security equipment by allowing you to TAP as many network segments as you may need to monitor with your peripheral network tools. Greater visibility accelerates problem resolution, reduces downtime and increases enterprise productivity.

The Single, Dual and Quad family of TAP products are compatible with all vendor hardware which will allow you to monitor all of your network segments through a single interface regardless of what network appliances you choose to deploy.

2.1 Single TAP Summary

The Single *FIBERTap*[™] is a single port device that provides a easy method to passively monitor fiber network traffic flowing between devices using your network analysis tools. Using your passive tap, your network analysis tools can be quickly and effectively deployed to the point of failure. Typically the passive tap is installed on a critical fiber link in the network where monitoring and analysis capabilities are important. The Single *FIBERTap*[™] features and benefits:

- Full duplex monitoring
- Non-intrusive passive monitoring device
- Rack mountable small form factor
- Standard dual SC connectors

2.2 Dual TAP Summary

The Dual *FIBERTap*[™] is a two port device that provides an easy method to passively monitor fiber network traffic flowing between devices using your network analysis tools. Typically the passive tap is installed on a critical fiber link in the network where monitoring and analysis capabilities are important. The Dual *FIBERTap*[™] features and benefits:

- Full duplex monitoring of two networks
- Non-intrusive passive monitoring device
- Rack mountable small form factor
- Standard LC or SC connectors

2.3 Quad TAP Summary

The Quad *FIBERTap*[™] is a four port device that provides an easy method to passively monitor fiber network traffic flowing between devices using your network analysis tools. Typically the passive tap is installed on a critical fiber link in the network where monitoring and analysis capabilities are important. The Quad *FIBERTap*[™] features and benefits:

- Full duplex monitoring of four networks
- Non-intrusive passive monitoring device
- Rack mountable small form factor
- Standard LC connectors

2.4 What Shipped?

Fiber Model Number Key

F50/50/xx-xxxx-xxx			
F50/50	/xx	-xxxx	-xxx
Fiber split ratio 50/50 or custom order ratio	62 micron 50 micron 9 micron	M = multimode fiber (SC connector) S = single-mode fiber (SC connector) #LCM = #LC connector multimode #LCS = #LC connector single-mode #SCM = #SC connector multimode #SCS = #SC connector single-mode	none = 1 Gigabit 10G = 10 Gigabit

NOTE: The fiber diameter, 62 micron, 50 micron or 9 micron should always match the fiber being tapped, plus the patch panels.

Single TAP

- 1 — F50/50/50-M or
F50/50/50-M-10G or
F50/50/62-M or
F50/50/62-M-10G or
F50/50/9-S or
F50/50/9-S-10G
- 1 — *QUICKinstall*

Dual TAP

- 1 — F50/50/50-2LCM or
F50/50/50-2LCM-10G or
F50/50/50-SCM or
F50/50/62-2LCM or
F50/50/62-2LCM-10G or
F50/50/62-SCM or
F50/50/9-2LCS or
F50/50/9-2LCS-10G
F50/50/9-2SCS
- 1 — *QUICKinstall*

Quad TAP

- 1 — F50/50/50-4LCM or
F50/50/50-4LCM-10G or
F50/50/62-4LCM or
F50/50/62-4LCM-10G or
F50/50/9-4LCS or
F50/50/9-4LCS-10G
- 1 — *QUICKinstall*

2.5 Single TAP Specifications

Channel: One

Cable Type: 50 or 62 micron multimode fiber
9 micron single-mode fiber

Port Connectivity: SC fiber connectors

In-Band Insertion Loss: T-3.5 to -4.5 dBm, typical

Power Requirements: none

Operating Temperature: 32° to 104° F _ 0° to 40° C

Storage Temperature: -22° to 149° F _ -30° to 65° C

Operating Range Relative Humidity: 5 to 90% non-condensing

Dimensions (H x W x D): includes RMC-3 rack mount bracket
1.125 x 5.750 x 5.625 inch
2.86 x 14.61 x 14.29 cm

Weight: 0.75 lbs; shipping: 1.65 lbs _ 0.34 kg; shipping; 0.75 kg

Warranty: Two (2) years - see '[Warranty](#)'²⁵ section for details.

2.6 Dual TAP Specifications

Channel: Two

Cable Type: 50 or 62 micron multimode fiber
9 micron single-mode fiber

Port Connectivity: LC or SC fiber connectors

In-Band Insertion Loss: T-3.5 to -4.5 dBm, typical

Power Requirements: none

Operating Temperature: 32° to 104° F _ 0° to 40° C

Storage Temperature: -22° to 149° F _ -30° to 65° C

Operating Range Relative Humidity: 5 to 90% non-condensing

LC Model Dimensions (H x W x D): includes RMC-3 rack mount bracket
1.125 x 5.750 x 5.625 inch
2.86 x 14.61 x 14.29 cm

LC Model Weight: 0.75 lbs; shipping: 1.65 lbs _ 0.34 kg; shipping; 0.75 kg

SC Model Dimensions (H x W x D): includes RMC-2 rack mount bracket
1.125 x 8.750.950 x 7.750 inch
2.86 x 22.22 x 19.69 cm

SC Model Weight: 0.75 lbs; shipping: 1.65 lbs _ 0.34 kg; shipping; 0.75 kg

Warranty: Two (2) years - see [Warranty](#)²⁵ section for details.

2.7 Quad TAP Specifications

Channel: Four

Cable Type: 50 or 62 micron multimode fiber
9 micron single-mode fiber

Port Connectivity: LC fiber connectors

In-Band Insertion Loss: T-3.5 to -4.5 dBm, typical

Power Requirements: none

Operating Temperature: 32° to 104° F _ 0° to 40° C

Storage Temperature: -22° to 149° F _ -30° to 65° C

Operating Range Relative Humidity: 5 to 90% non-condensing

Dimensions (H x W x D): includes RMC-2 rack mount bracket
1.125 x 8.750.950 x 7.750 inch
2.86 x 22.22 x 19.69 cm

Weight: 0.75 lbs; shipping: 1.65 lbs _ 0.34 kg; shipping; 0.75 kg

Warranty: Two (2) years - see '[Warranty](#)'²⁵ section for details.

3 Functional and Front Panel Diagrams

Functional and front panel diagrams of the Single, Dual and Quad models are provided in this section.

3.1 Single TAP

Model Number Key

F50/50/xx-xxxx-xxx			
F50/50 Fiber split ratio 50/50 or custom order ratio	/xx 62 micron 50 micron 9 micron	-xxxx M = multimode fiber (SC connector) S = single-mode fiber (SC connector) #LCM = #LC connector multimode #LCS = #LC connector single-mode #SCM = #SC connector multimode #SCS = #SC connector single-mode	-xxx none = 1 Gigabit 10G = 10 Gigabit

NOTE: The fiber diameter, 62 micron, 50 micron or 9 micron should always match the fiber being tapped, plus the patch panels.

Single 1G SC TAP: F50/50/9-S or F50/50/50-M or F50/50/62-M

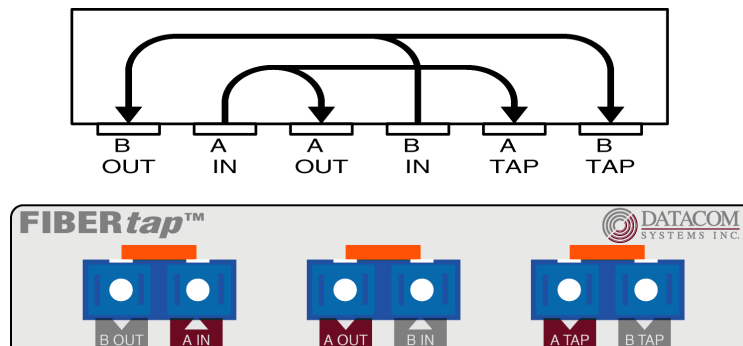

Single 10G SC TAP: F50/50/9-S-10G or F50/50/50-M-10G or F50/50/62-M-10G

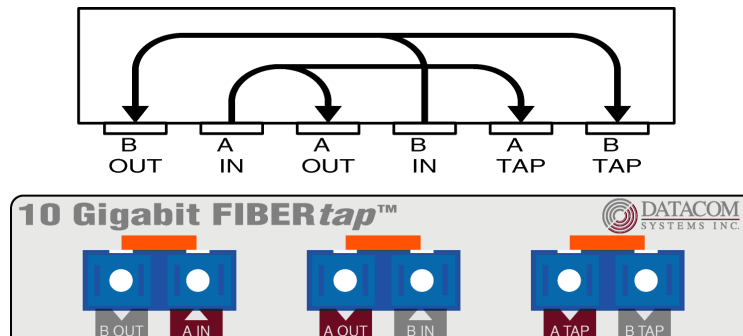

3.2 Dual TAP

Model Number Key

F50/50/xx-xxxx-xxx			
F50/50 Fiber split ratio 50/50 or custom order ratio	/xx 62 micron 50 micron 9 micron	-xxxx M = multimode fiber (SC connector) S = single-mode fiber (SC connector) #LCM = #LC connector multimode #LCS = #LC connector single-mode #SCM = #SC connector multimode #SCS = #SC connector single-mode	-xxx none = 1 Gigabit 10G = 10 Gigabit

NOTE: The fiber diameter, 62 micron, 50 micron or 9 micron should always match the fiber being tapped, plus the patch panels.

Dual 1G LC TAP: F50/50/9-2LCS or F50/50/50-2LCM or F50/50/62-2LCM

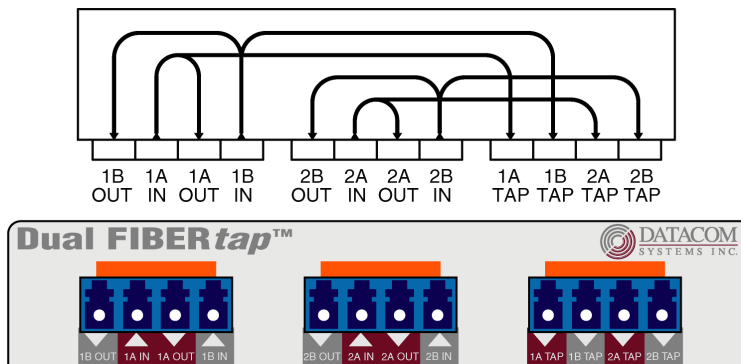

Dual 1G SC TAP: F50/50/9-2SCS or F50/50/50-2SCM or F50/50/62-2SCM

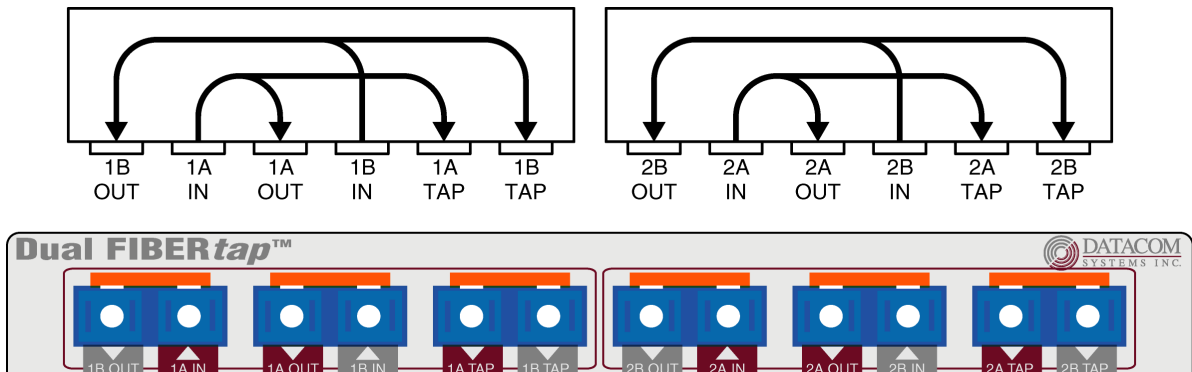

Dual 10G LC TAP: F50/50/9-2LCS-10G or F50/50/50-2LCM-10G or F50/50/62-2LCM-10G

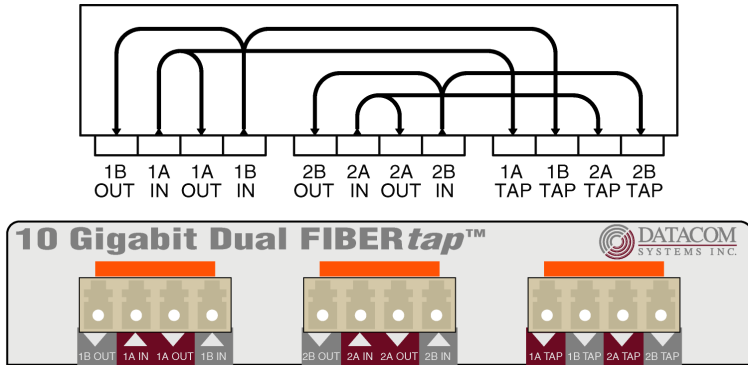

3.3 Quad TAP

Model Number Key

F50/50/xx-xxxx-xxx			
F50/50 Fiber split ratio 50/50 or custom order ratio	/xx 62 micron 50 micron 9 micron	-xxxx M = multimode fiber (SC connector) S = single-mode fiber (SC connector) #LCM = #LC connector multimode #LCS = #LC connector single-mode #SCM = #SC connector multimode #SCS = #SC connector single-mode	-xxx none = 1 Gigabit 10G = 10 Gigabit

NOTE: The fiber diameter, 62 micron, 50 micron or 9 micron should always match the fiber being tapped, plus the patch panels.

Quad 1G LC TAP: F50/50/9-4LCS or F50/50/50-4LCM or F50/50/62-4LCM

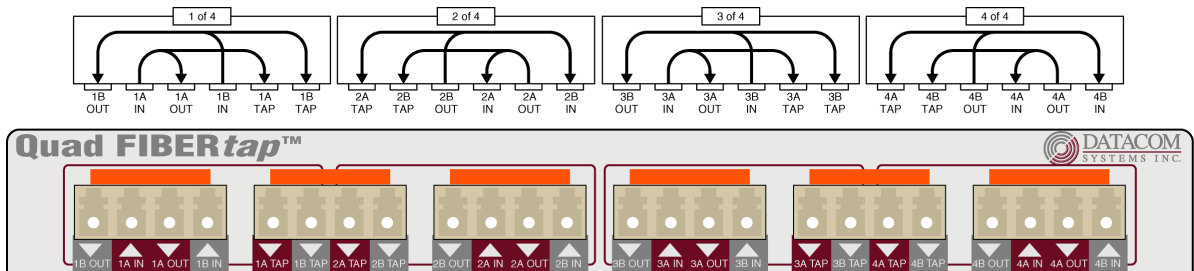

Quad 10G LC TAP: F50/50/9-4LCS-10G or F50/50/50-4LCM-10G or F50/50/62-4LCM-10G

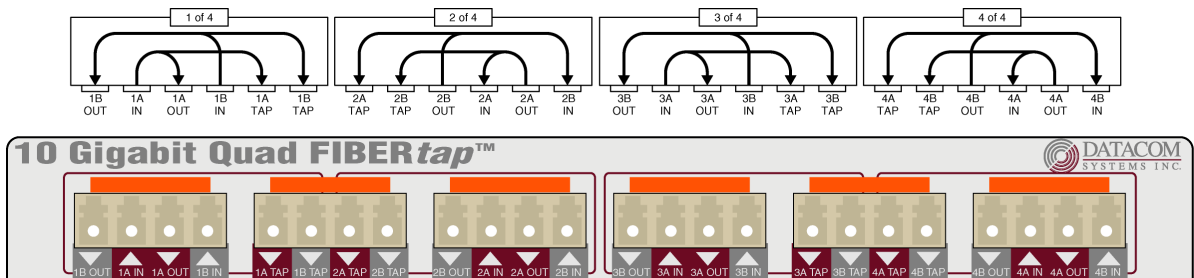

4 Hardware Installation

This section describes the Single, Dual and Quad hardware installation at your network site.

4.1 How Fiber TAPs Work

Fiber TAPs are essentially fiber splitters and as such are completely passive (no power requirements.) Fiber splitters divide the light into two separate channels, which takes signal strength from one fiber and divides it into two (or more) fibers. When using a splitter, make sure the 'light budget' allows for splitting a percentage of light from the main connection.

Splitters are really 4 port devices. When they are manufactured 2 fibers are twisted together until the desired split ratio is obtained and they are fused together. The 4TH leg is then cut off and terminated. If light is not entering the splitter in the proper direction the expected light out the TAP port will be inadequate for the network tool. This is a common problem and will result in link faults on the network tools. To remedy the problem, simply swap the network connections into the splitter for proper connectivity and link activity. All fiber connectors (SC and LC) are keyed, if the key is pointing up Rx is on the right and Tx is on the left. Tx from the network device, the fiber with light, should enter the Rx port on the splitter.

50/50 Splitters

approximate 4dBm drop

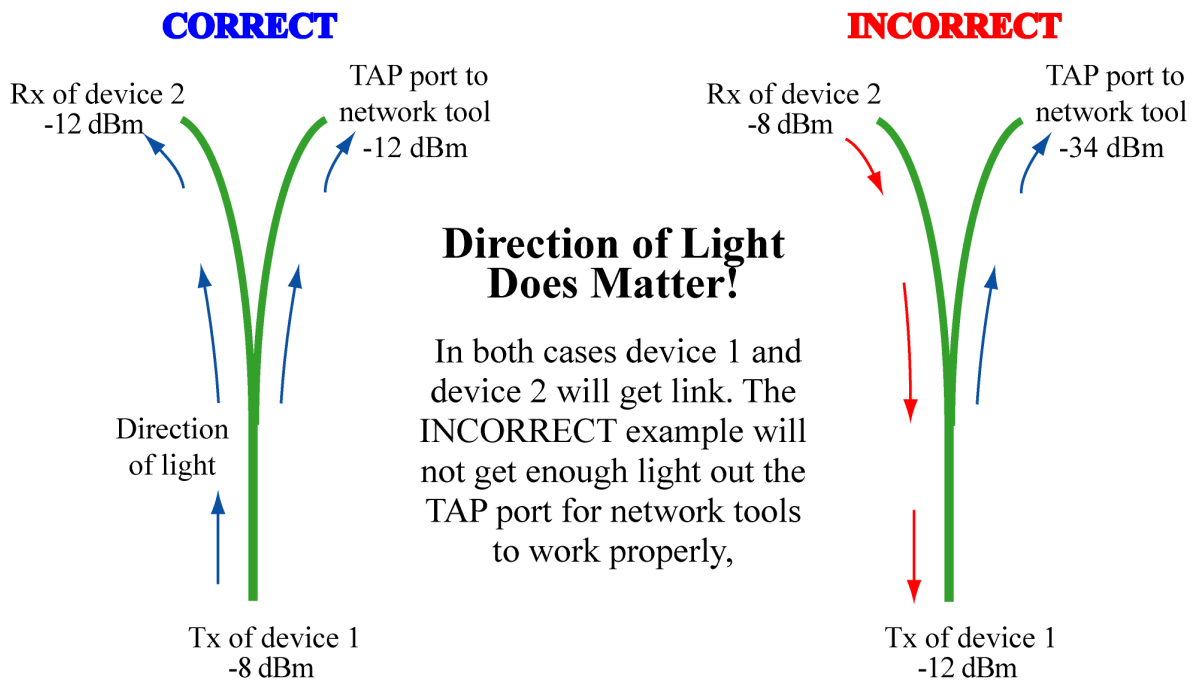

4.2 Single TAP

A Single 1G or 10G hardware installation using a typical Single 10G TAP is shown.

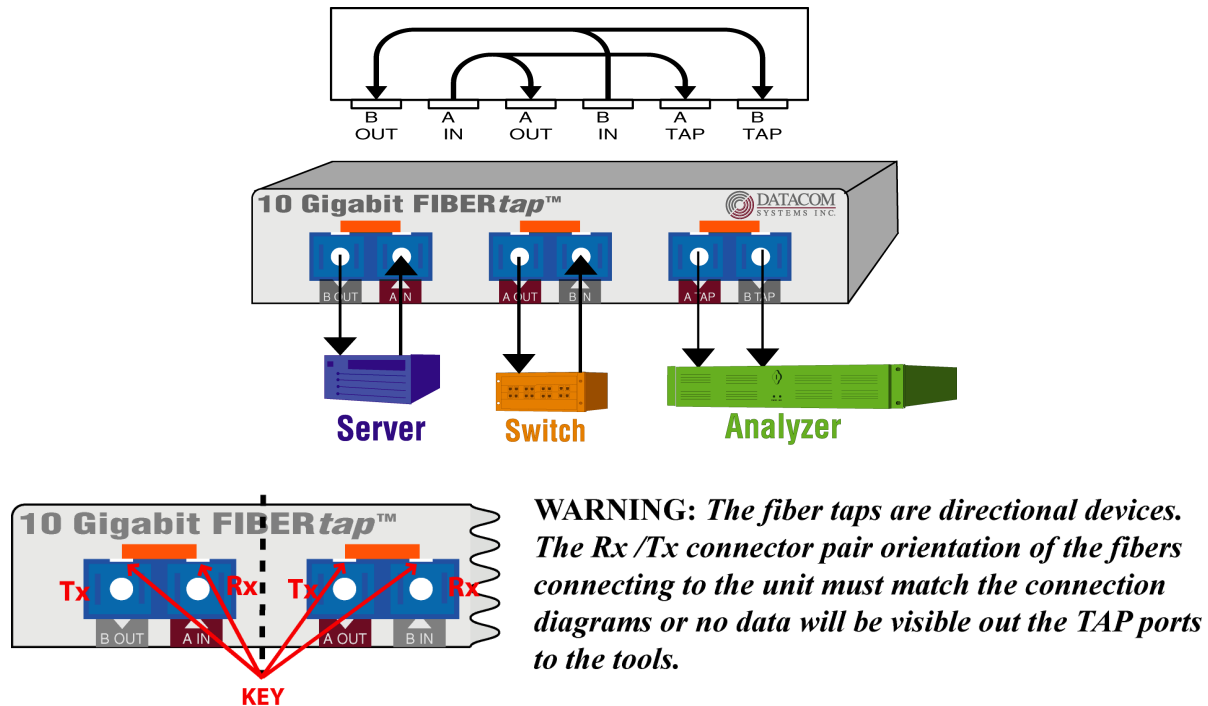

IMPORTANT: A color rectangle near each fiber connector indicates the network fiber mode implementation for each connector. Orange is 62 micron multimode, aqua is 50 micron multimode and yellow is 9 micron single-mode.

NOTE: Network connector sequence; slot key up; left to right: Tx and Rx (TX is light out of transmitter and Rx is light into receiver.) The TAP connector sequence is Tx and Tx.

Step 1. Connect the fiber cables from one network end device Rx and Tx optic connector, respectively, to the FIBERtap™ **B OUT** and **A IN** (Tx and Rx, respectively) connectors.

Step 2. Connect the other network end device fiber cables from the network device Rx and Tx optic connector, respectively, to the **A OUT** and **B IN** (Tx and Rx, respectively) connectors.

Step 3. Connect the analysis tool first adapter card Rx port connector to the FIBERtap™ **A TAP** connector using a simplex fiber cable..

Step 4. Connect the analysis tool second adapter card Rx port connector to the **B TAP** connector using another simplex fiber cable.

Step 5. Confirm that the network link works and the monitoring tool is receiving traffic. This completes the Single FIBERtap™ hardware installation.

4.3 Dual LC TAP

A Dual 1G LC or 10G LC hardware installation using a typical 10G LC TAP is shown.

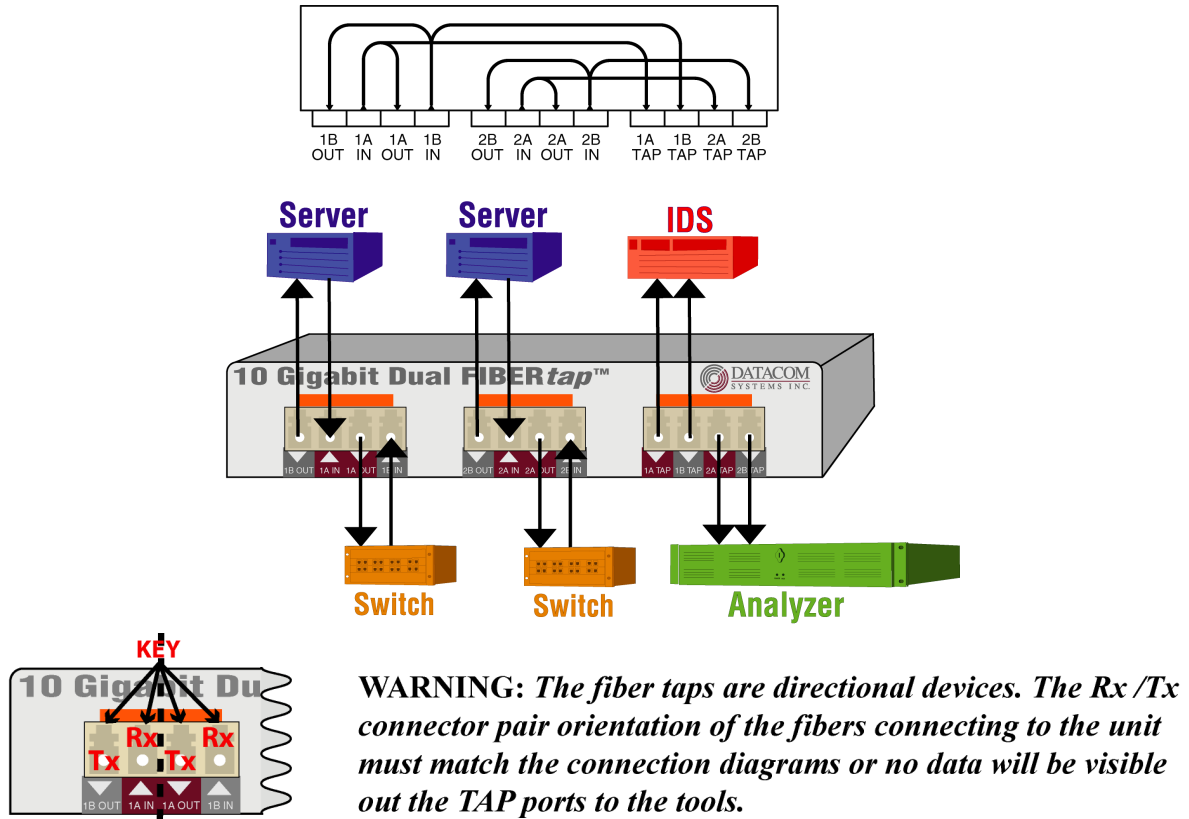

IMPORTANT: A color rectangle near each fiber connector indicates the network fiber mode implementation for each connector. Orange is 62 micron multimode, aqua is 50 micron multimode and yellow is 9 micron single-mode.

NOTE: Network connector sequence; slot key up; left to right: Tx and Rx (TX is light out of transmitter and Rx is light into receiver.) The TAP connector sequence is Tx and Tx.

Step 1. Connect the fiber cables from one network end device Rx and Tx optic connector, respectively, to the FIBERTap™ **1B OUT** and **1A IN** (Tx and Rx, respectively) connectors.

Step 2. Connect the other network end device fiber cables from the network device Rx and Tx optic connector, respectively, to the **1A OUT** and **1B IN** (Tx and Rx, respectively) connectors.

Step 3. Connect the fiber cables from the second network end device Rx and Tx optic connector, respectively, to the FIBERTap™ **2B OUT** and **2A IN** (Tx and Rx, respectively) connectors.

Step 4. Connect the second other network end device fiber cables from the network device Rx and Tx optic connector, respectively, to the **2A OUT** and **2B IN** (Tx and Rx, respectively) connectors.

Step 5. Connect the analysis tool first adapter card Rx port connector to the FIBERTap™ **1A TAP** connector using a simplex fiber cable..

Step 6. Connect the analysis tool second adapter card Rx port connector to the **1B TAP** connector using another simplex fiber cable..

Step 7. Connect the second analysis tool first adapter card Rx port connector to the FIBERTap™ **2A TAP** connector using a simplex fiber cable..

Step 8. Connect the second analysis tool second adapter card Rx port connector to the **2B TAP** connector using another simplex fiber cable.

Step 9. Confirm that the network links work and monitoring tools are receiving traffic. This completes the Dual FIBERTap™ hardware installation.

4.4 Dual SC TAP

A Dual 1G SC or 10G SC hardware installation using a typical 10G LC TAP is shown.

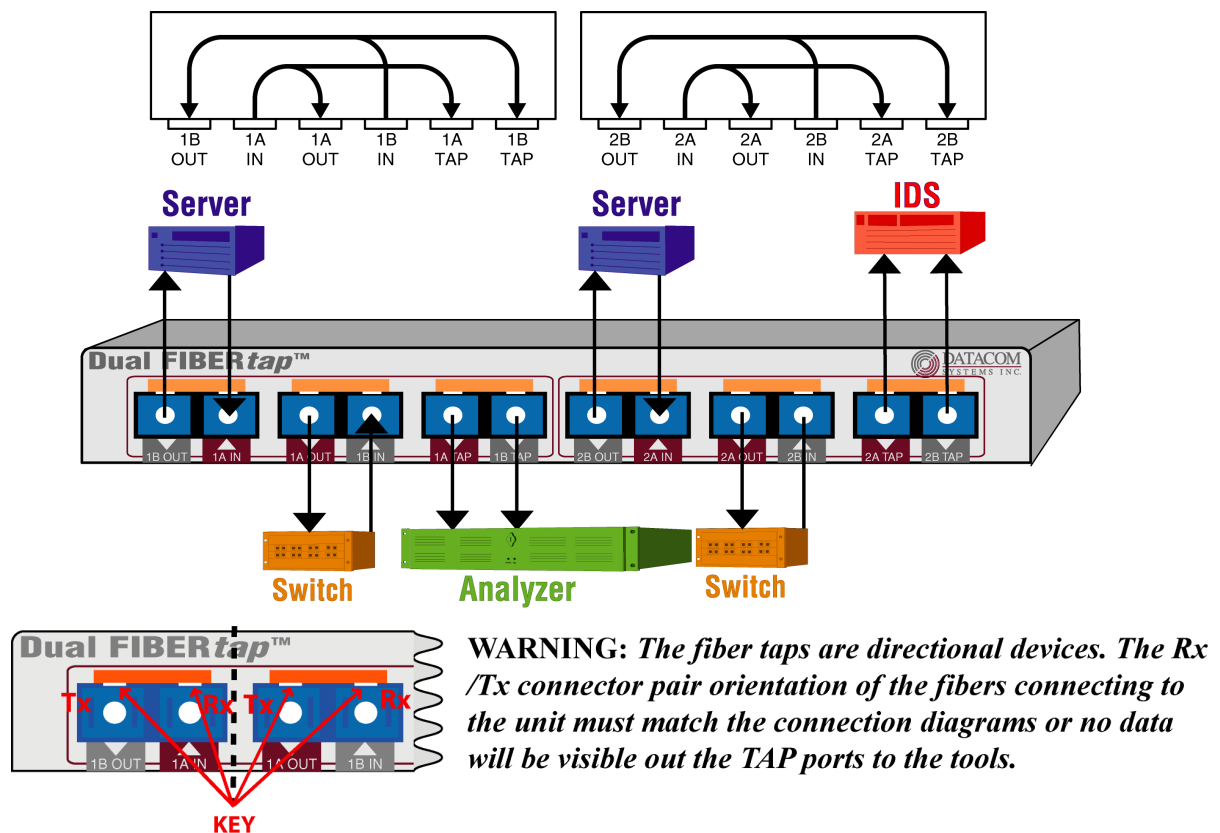

IMPORTANT: A color rectangle near each fiber connector indicates the network fiber mode implementation for each connector. Orange is 62 micron multimode, aqua is 50 micron multimode and yellow is 9 micron single-mode.

NOTE: Network connector sequence; slot key up; left to right: Tx and Rx (TX is light out of transmitter and Rx is light into receiver.) The TAP connector sequence is Tx and Tx.

Step 1. Connect the fiber cables from one network end device Rx and Tx optic connector, respectively, to the FIBERtap™ **1B OUT** and **1A IN** (Tx and Rx, respectively) connectors.

Step 2. Connect the other network end device fiber cables from the network device Rx and Tx optic connector, respectively, to the **1A OUT** and **1B IN** (Tx and Rx, respectively) connectors.

Step 3. Connect the fiber cables from the second network end device Rx and Tx optic connector, respectively, to the FIBERtap™ **2B OUT** and **2A IN** (Tx and Rx, respectively) connectors.

Step 4. Connect the second other network end device fiber cables from the network device Rx and Tx optic connector, respectively, to the **2A OUT** and **2B IN** (Tx and Rx, respectively) connectors.

Step 5. Connect the analysis tool first adapter card Rx port connector to the FIBERtap™ **1A TAP** connector using a simplex fiber cable..

Step 6. Connect the analysis tool second adapter card Rx port connector to the **1B TAP** connector using another simplex fiber cable..

Step 7. Connect the second analysis tool first adapter card Rx port connector to the FIBERtap™ **2A TAP** connector using a simplex fiber cable..

Step 8. Connect the second analysis tool second adapter card Rx port connector to the **2B TAP** connector using another simplex fiber cable.

Step 9. Confirm that the network links work and monitoring tools are receiving traffic. This completes the Dual FIBERtap™ hardware installation.

4.5 Quad TAP

A Quad 1G LC or 10G LC hardware installation using a typical 10G LC TAP is shown and only one network connection (1 of 4) will be shown for clarity.

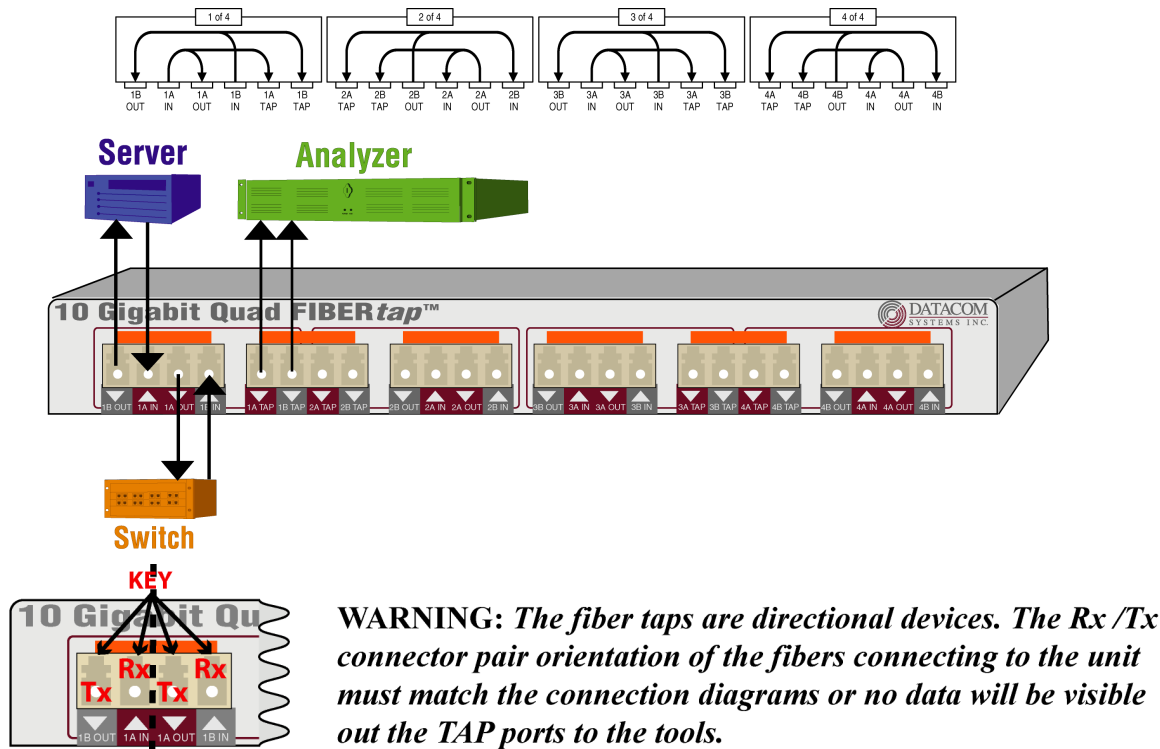

IMPORTANT: A color rectangle near each fiber connector indicates the network fiber mode implementation for each connector. Orange is 62 micron multimode, aqua is 50 micron multimode and yellow is 9 micron single-mode.

NOTE: Network connector sequence; slot key up; left to right: Tx and Rx (TX is light out of transmitter and Rx is light into receiver.) The TAP connector sequence is Tx and Tx.

Step 1. Connect the fiber cables from one network (1 of 4) end device Rx and Tx optic connector, respectively, to the FIBERtap™ **1B OUT** and **1A IN** (Tx and Rx, respectively) connectors.

Step 2. Connect the other network (1 of 4) end device fiber cables from the network device Rx and Tx optic connector, respectively, to the **1A OUT** and **1B IN** (Tx and Rx, respectively) connectors.

Step 3. Connect the analysis tool first adapter card Rx port connector to the FIBERtap™ **1A TAP** connector using a simplex fiber cable..

Step 4. Connect the analysis tool second adapter card Rx port connector to the **1B TAP** connector using another simplex fiber cable..

Step 5. Repeat Step 1 through 4 for the remaining network connections (2 of 4, 3 of 4 and 4 of 4) desired replacing the appropriate number (i.e. **2, 3, or 4**) for the **OUT, IN** and **TAP FIBERTap™** connections.

Step 6. Confirm that the network links work and monitoring tools are receiving traffic. This completes the Quad FIBERTap™ hardware installation.

5 Customer Service

This *QUICKinstall* was written to help you get to know your new TAP quickly and easily. We would welcome any comments or suggestions you may have regarding this *QUICKinstall*. Please send your remarks and recommendations via mail, telephone, facsimile, or Internet E-mail.

Datacom Customer Service is available via telephone, facsimile, and Internet E-mail. Outside of support hours, please leave a voice message and our Customer Service Staff will return your call as soon as possible.

Mail: Datacom Systems, Inc.
Customer Service
9 Adler Drive
East Syracuse, NY 13057-1290
Tel: (315) 463-9541
FAX: (315) 463-9557
E-mail: support@datacomsystems.com

5.1 Internet

You can obtain additional information about Datacom Systems, Inc. and its products and services from the Internet at:

<http://www.datacomsystems.com>.

5.2 Warranty

Datacom Systems, Inc. (DSI) warrants that the hardware which it supplies will be free from significant defects in materials and workmanship for a period of two years from the date of delivery (Warranty Period), under normal use and conditions. In the event of any such defect, you can return an item of defective hardware, freight prepaid, to DSI during the Warranty Period, and DSI will repair or replace the defective equipment and return it to you, freight prepaid. If DSI determines that the equipment is not defective, it will return it to you, freight collect. DSI shall have no responsibility for any deficiency resulting from accidents, misuse, modifications, power disturbances (including use of a power supply not specified by DSI), or various other forms of disaster, e.g., earthquakes, floods, etc.

PLEASE DO NOT ATTEMPT TO RETURN ANY ITEM PRIOR TO RECEIVING A RETURN MATERIAL AUTHORIZATION (RMA) NUMBER FROM DATACOM CUSTOMER SERVICE AT (315) 463-9541 or support@datacomsystems.com

5.3 Limits of Liability

The warranties set forth above are exclusive and in lieu of all other warranties. Datacom Systems, Inc. (DSI) makes no other warranties, expressed or implied, and DSI expressly disclaims all other warranties, including but not limited to implied warranties of merchantability and fitness for a particular purpose. Moreover, the provisions set forth above state DSI's entire responsibility and your sole and exclusive remedy with respect to any breach of warranty or contract.

No liability for consequential damages. Under no circumstances and under no theory of Liability shall DSI be liable for costs of procurement of substitute products or services, lost profits, lost savings, loss of information or data, or any other special, indirect, consequential or incidental damages, arising in any way out of the sale of, use of, or inability to use, any DSI product or service, even if DSI has been advised of the possibility of such damages.

Datacom Systems Inc.

9 Adler Drive • East Syracuse, NY 13057

TEL: (315) 463-9541 • FAX: (315) 463-9557

<http://www.datacomsystems.com>



Datacom Systems Inc

Access Your Network™